

FORMECA

**AUTOMATIC BOX
FORMING MACHINES**

Formeca **SB-20**

Packaging boxes must be especially durable when transporting heavy bulk goods. The Formeca SB-20 box forming machine uses hot melt adhesive and a forming tool to make corner-reinforced corrugated board boxes with double-thickness reinforced edges on the long side. The stainless steel SB-20 is particularly suitable for making sturdy fruit and vegetable boxes.

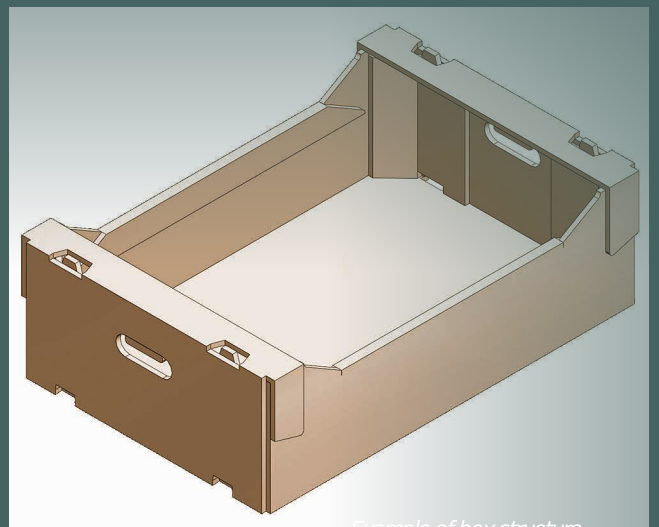

Example of box structure.

The SB-20 machine has an elevator type blank magazine that can be rapidly and ergonomically refilled using a carriage, even while the machine is operating. The box size can be changed in a few minutes using replacement parts equipped with quick-fastening locks and simple adjustment procedures. All Formeca packaging machines are made in Finland. They can be modified for various box structures according to the requirements of the customer's packaging operation.

- helpful display panel available in various languages
- capacity of up to 20 boxes per minute, adjustable operating speed
- connections: 400VAC/50Hz electric power and 6 bar compressed air
- adjustable for boxes of varying size
- machine dimensions (length/width/height) 5500 x 2100 x 2300 mm
- box size minimum 300 x 400 mm and maximum 400 x 600 mm

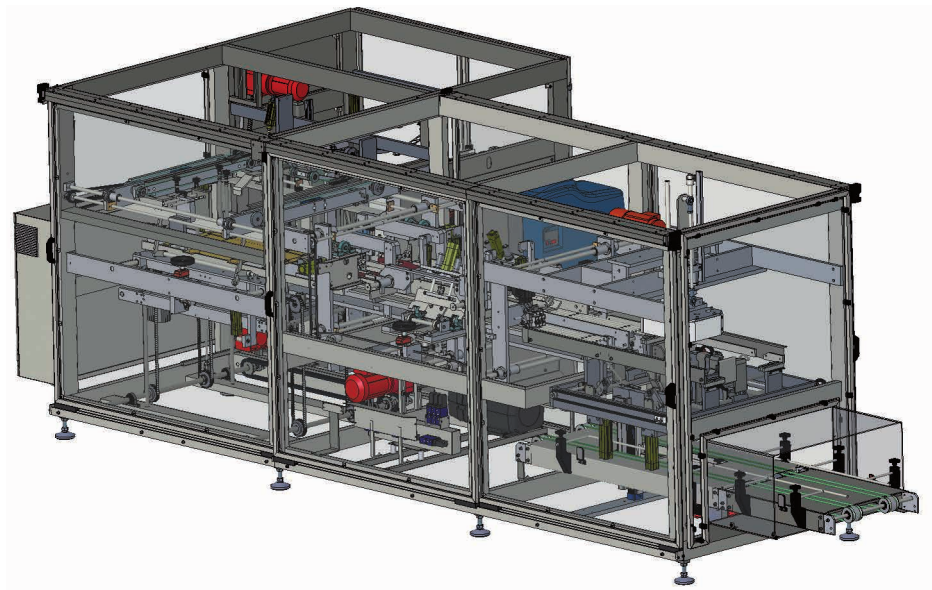
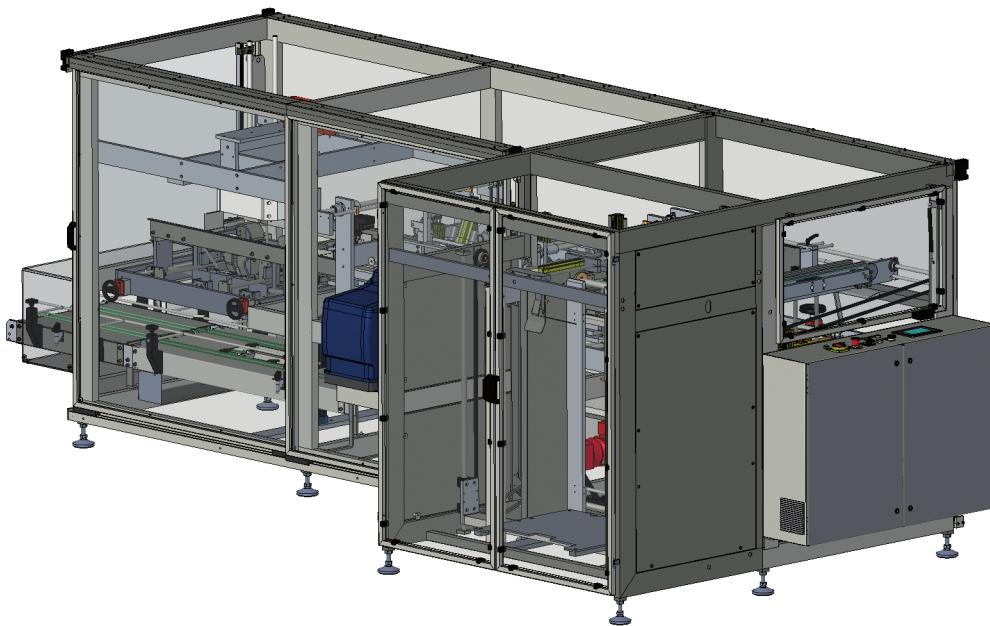

Formeca is part of the Finnish technology company Orfer Oy.

Orfer Oy
Vaakatie 9, FI-16300 Orimattila FINLAND
Tel. +358 (0)3 884 11
www.orfer.fi

ORFER 